

USER MANUAL

Power GUARD UPS

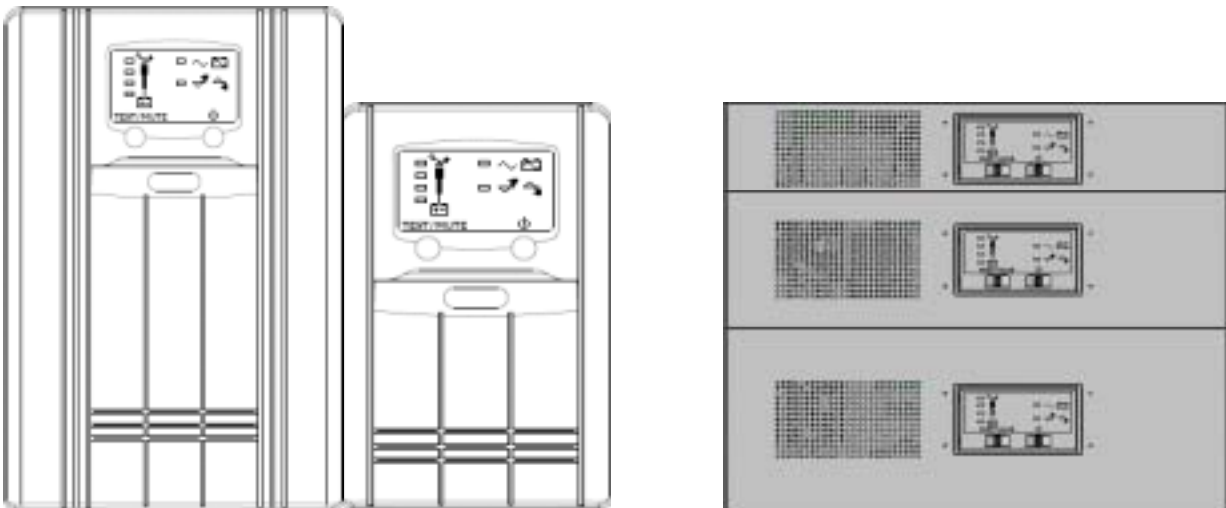

Uninterruptible Power System

IMPORTANT SAFETY INSTRUCTIONS

SAVE THESE INSTRUCTIONS – This manual contains important instructions for Power GUARD that should be followed during installation and maintenance of the UPS and batteries. Read all safety and operating instructions before operating the UPS. Adhere to all warnings on the unit and in this manual. Follow all operating and user instruction.

CONTENTS

1. Introduction	1
2. Safety – CAUTION!	1 - 3
3. System Concept	3 - 5
4. System Description	6 - 10
5. Installation	10 -11
6. Operation	11 -12
7. Trouble Shooting	13 -15
8. Specification	15 -16

1. Introduction

This series are Line Interactive Sinewave UPS series and provide conditioned power to microcomputer and other sensitive electronic equipment.

Upon generation, AC power is clean and stable. However, during transmission it may be subject to voltage sags, spikes, or complete power failure which may interrupt computer operations, cause data loss, or even damage equipment. This series protects equipment from these disturbances.

This series UPS is a compact, and Line Interactive UPS. A “Line Interactive” UPS continuously conditions and regulates its output voltage, whether the mains power is present or not. It supplies connected equipment with clean sinewave power, to simulate as much as possible, the power generated by the mains. Sensitive electronic equipment operates best from sinewave power.

For ease of use, this series contain a light emitting diode (LED) bar display to indicate either “load percentage” or “battery capacity” depending upon the mode of operation. It also provides self diagnostics and two levels of alarms when the unit is operating on battery.

This series have an interface port for communications between the UPS and a LAN server or other computer system. This port provides detailed operating information including voltages, currents, and alarm status to the host system when used in conjunction with C-eyes software.

2. Safety – CAUTION

WARNING: Do not attempt to service this product yourself except to replace the battery. Opening or removing the cover may expose you to dangerous voltages, even when the AC cord is disconnected from the electrical outlet. Refer all servicing to qualified service personnel.

1. This product is designed for Commercial/Industrial use only. It is not intended for use with life support and other designated “critical” devices.

Maximum load must not exceed that shown on the UPS rating label. If uncertain, consult your dealer. See Limited Warranty.

2. When replacing the batteries, use the appropriate replacement battery kit. Proper disposal of batteries is required. Refer to your local laws and regulations for disposal requirements.
3. Always turn off the UPS and unplug it before starting the battery replacement procedure. To replace batteries, refer to the battery replacement procedure. If you feel unqualified to replace the batteries, do not open the battery door. Refer all servicing to qualified service personnel.
4. **CAUTION:** Do not open or mutilate the batteries. Released electrolyte is harmful to skin and eyes and may be toxic.
5. The mains supply socket or means of isolation must be within 2 meters of the equipment and accessible to the operator. The UPS is designed for data processing equipment.
6. The UPS comes with two output power leads with molded connectors. Do not modify the output power leads. Consult dealer if connector does not match the load socket. UPS must be earthed at all times while in use. Turn UPS off before unplugging it, or the safety earth will be removed.
7. The UPS output supply sockets may electrically live whenever the input power lead is plugged into the mains supply socket. Turning the UPS off does not electrically isolate the internal parts. To isolate the UPS, turn the UPS off and then isolate it from the mains supply.

CAUTION: The UPS and connected load total earth leakage current must not exceed 3.5 milliamperes. If the connected load earth leakage current is likely to exceed 2.5 milliamperes or you are unsure, then convert the input lead attachment to either a fixed wiring installation or an industrial plug/socket (e.g. CEE 17 connector). This task should be carried out by a competent electrical engineer who is conversant with local electrical codes/regulations.

8. Operate UPS only from a properly earth, 50Hz or 60Hz, 220-240 VAC mains supply. Models are available from 100-127VAC supply voltages.
9. Route power supply leads so they are not walked on or pinched.
10. Never block or insert any object into the ventilation holes or other openings. Maintain a minimum clearance of 100mm (4 inches) all around the UPS for proper airflow and cooling.
11. Operate the UPS in an indoor environment only, with an ambient temperature range of 0°C to 40°C (32°F to 104°F). Install it in a clean environment, free from moisture, flammable liquids, gasses, or corrosive substances.
12. Storing magnetic media on top of the UPS may result in data loss or corruption.
13. Turn the UPS off and unplug the UPS before cleaning. Use only a soft cloth, never liquid or aerosol cleaners.
14. This equipment can be operated by individuals without previous training.

3. System Concept

3-1 UPS Operation

Line Mode: When input AC is normal, I/P voltage delivers directly to O/P without draining battery energy. They include normal, buck and boost modes. The O/P voltage is almost the same as I/P voltage in normal mode. The O/P voltage is almost 1.15/1.12 (1.12) times of I/P voltage in boost mode for 120V / 220V (230V/240V) models and 0.88 / 0.90 (0.90) times of I/P voltage in buck mode for 120V / 220V (230V/240V) models.

Refer to Figures 1, 2, and 3.

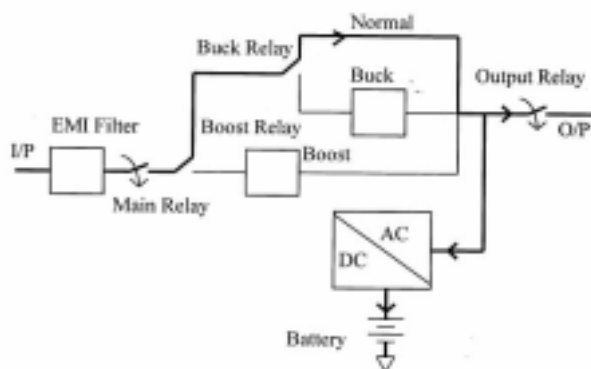

Fig. 1 UPS in Normal Mode

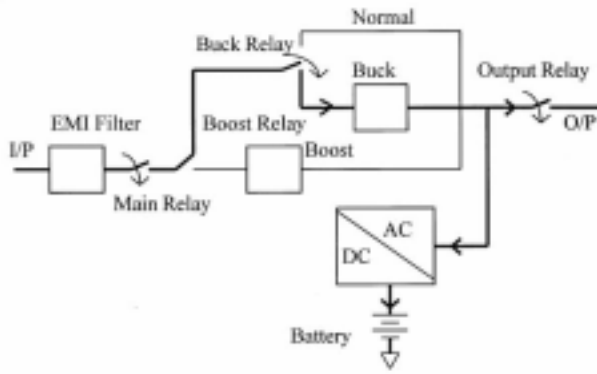

Fig. 2. UPS in Buck Mode

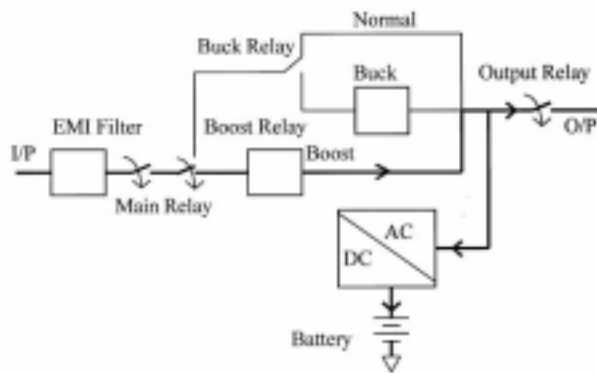

Fig. 3. UPS in Boost Mode

Battery Mode: When input AC source (utility) is abnormal, O/P is supplied by batteries. Its output waveform is sine wave.

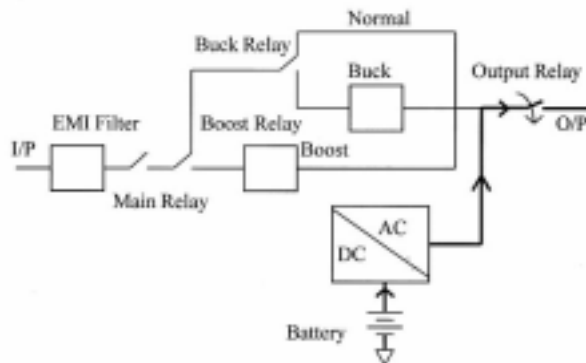

Fig. 4. UPS in Battery Mode

3-2 Transient voltage surge suppression (TVSS) and EMI/RFI filters

These UPS components provide surge protection and filter electromagnetic interference (EMI) and radio frequency interference (RFI). They minimize any surges or interference present in the mains line and keep the sensitive equipment protected.

3-3 Automatic voltage regulator

In normal operation, the automatic voltage regulator (AVR) passes mains AC power to the connected load. When mains power voltage is outside acceptable limits, the AVR activates. It raises undervoltage power and lowers overvoltage power. This keeps the UPS output voltage within the connected equipment's tolerances and allows wide mains voltage fluctuations without utilizing battery power.

3-4 Bi-Directional converter

In normal operation, the bi-directional converter "converts" mains AC power into regulated DC power to "float" charge the battery system. Upon a mains power failure, the bi-directional converter receives its required energy from the battery and "inverts" it into precise, regulated sinewave AC power. Charging takes place whenever the UPS is plugged into the wall outlet and mains power is within acceptable limits.

3-5 Battery

This series utilizes valve regulated, nonspillable, lead acid batteries. At typical room temperatures and with the UPS float charging, the battery system will last many years. For battery run times, refer to Typical Battery Discharge Curves.

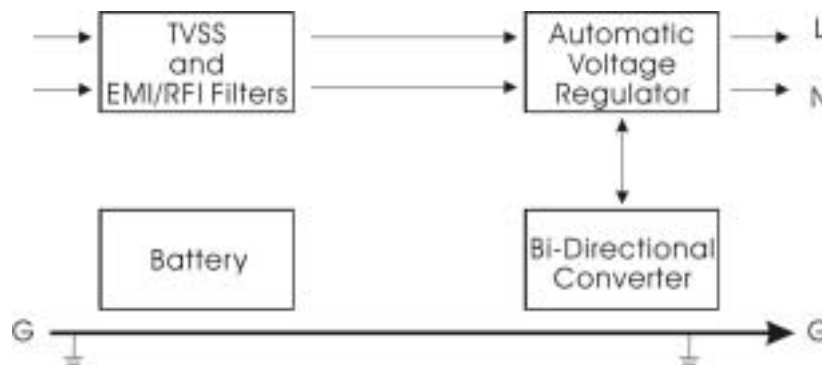

4. System Description

Front Panel—

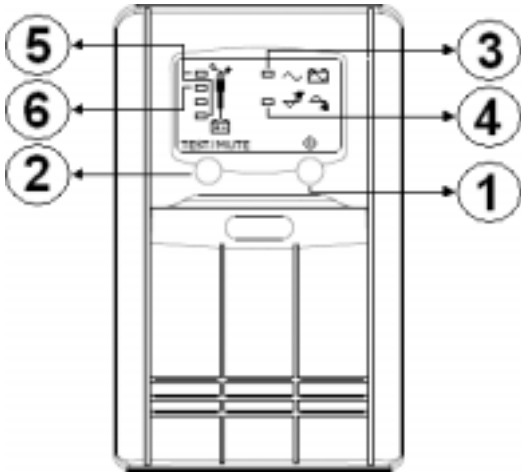

1KVA/1.25KVA

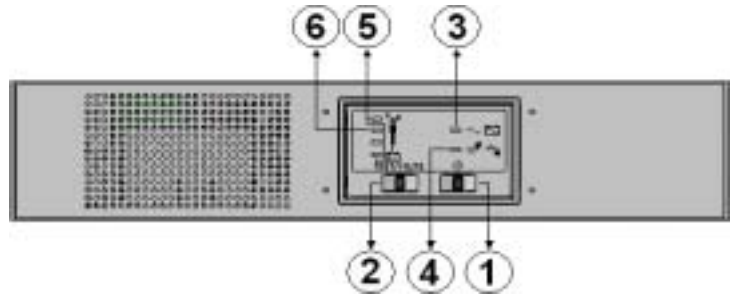

1KVA/1.25KVA

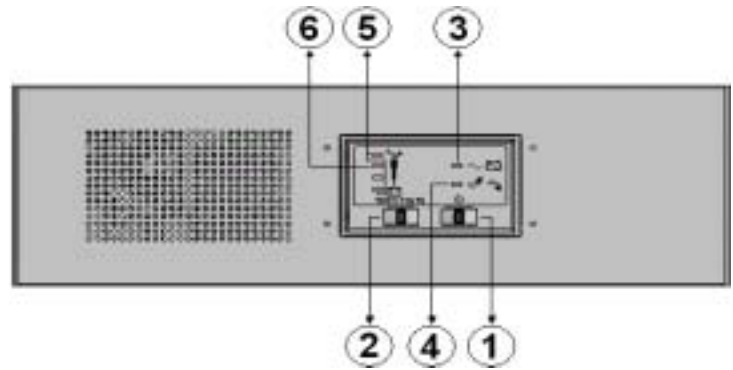

2KVA/2.5KVA

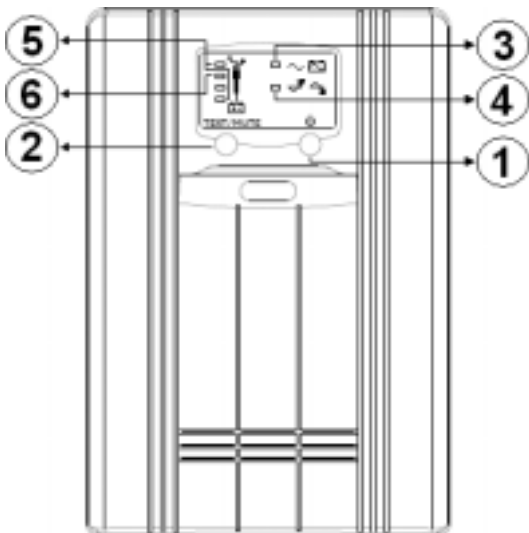

2KVA/2.5KVA/3KVA/3.5KVA

Tower

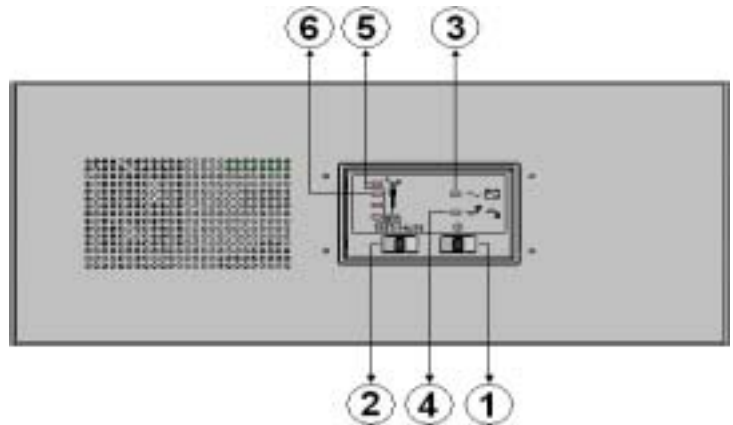

3KVA/3.5KVA

Rack

1. **Power Switch:**

The power switch controls output power to connected loads.

CAUTION: Pressing the power switch when AC mains is not present will cause the UPS to begin operating from battery. This should not be performed unless the UPS input is connected to a properly earthed socket.

2. **Alarm Silence/ Battery Test Button**

The Alarm Silence/Battery Test Button serves a dual purpose. During normal mode operation, press button for at least one half second to test capacity of the battery system. The UPS will operate in battery mode for approximately 15 seconds. The illuminated LED indicators in Load/Battery Level determine battery mode capacity in 25% increments.

During battery mode operation or active alarm condition, this button functions as the alarm silence feature. Pressing this button for at least one half second will silence the alarm. After the alarm is silenced, the UPS will reactivate the alarm system to alert of additional problems. The low battery alarm is the single alarm that cannot be silenced. During a Battery Test, if the top two LEDs do not illuminate, allow the UPS to recharge the batteries for 24 hours. After 24 hours, retest the batteries. If the batteries have been retested and the top two LEDs still do not illuminate, contact your dealer for a battery replacement kit.

3. **Mains/Battery Status Indicator (Green LED)**

An illuminated LED indicates the power button is on and mains power is available. Green LED flashing 5 times along with an alarm signifies mains voltage is out of specification and UPS is operating in battery mode.

4. **Boost and Buck AVR Indicator (Yellow LED)**

An illuminated LED indicates the UPS is correcting mains power, due to a mains overvoltage or undervoltage condition.

5. **Load/Battery Level Indicators (All Green LEDs)**

The Load/Battery Level Indicators have dual functions. During normal mode operation, LED indicators display electrical load placed upon the UPS; and during battery mode operation, LED indicators display battery

6. **Fault Indicator (Green LED)**

The Fault Indicator is the second bottommost LED (contained in load/battery level indicators). A flashing LED indicates the UPS has detected a problem. An alarm sounds to alert that the UPS requires attention. Refer to Trouble Shooting Guide.

Audible Alarm Condition—

Condition	Alarm
Battery Mode (Power Failure)	One short beep every 10 seconds; more than 2 minutes of run time remaining
Low Battery	Two short beeps every 5 seconds; less than 2 minutes of run time remaining
Battery Replacement	2-second beep every minute
Overload	One short beep every second
UPS fault	Continuously Sounding

Back Panel for Tower Case—

1KVA/1.25KVA

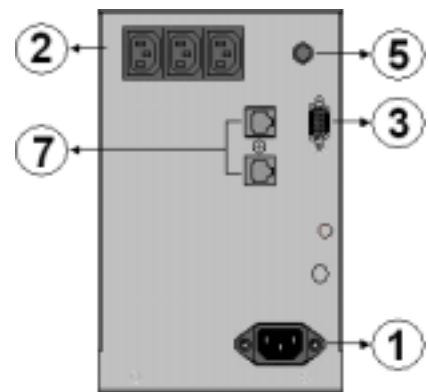
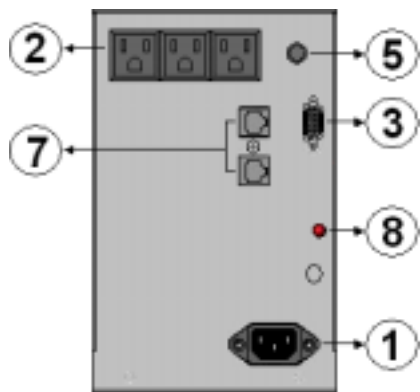

2KVA/2.5KVA

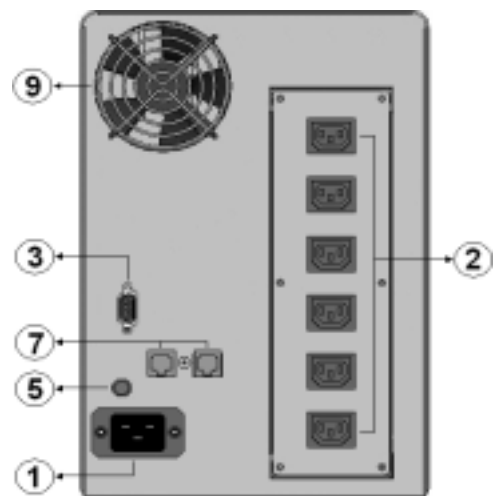
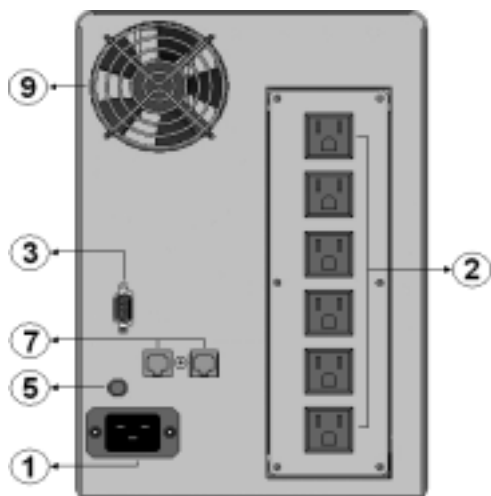

3KVA/3.5KVA

(For 110V only)

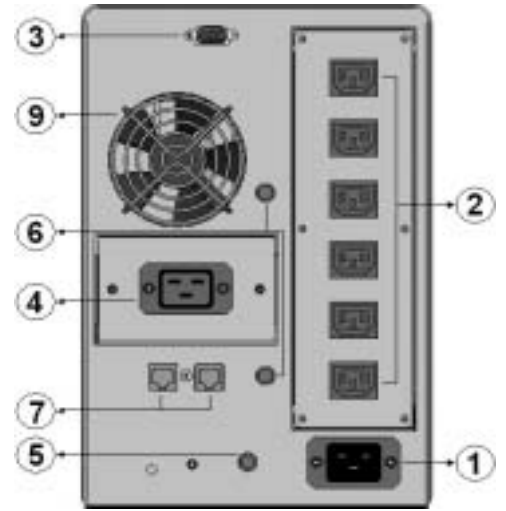
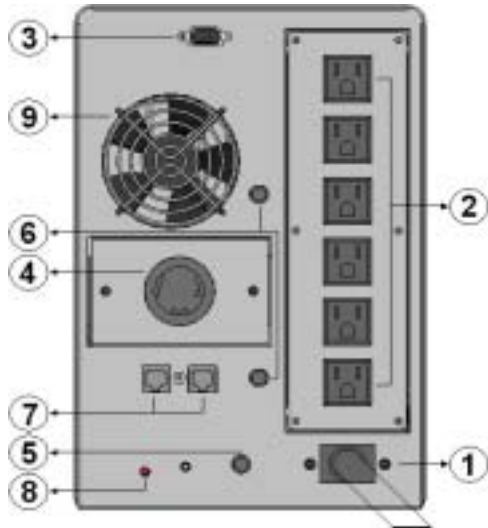

Back Panel for Rack Case—

1KVA/1.25KVA

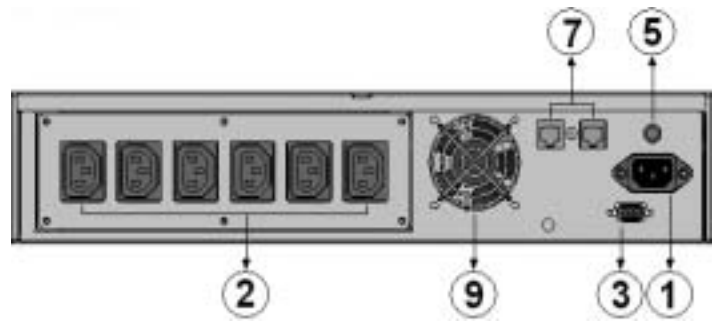
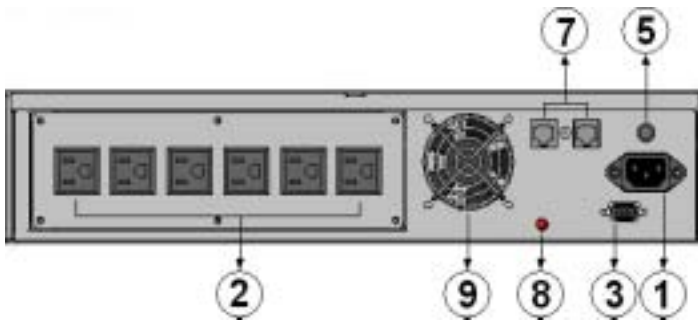

2KVA/2.5KVA

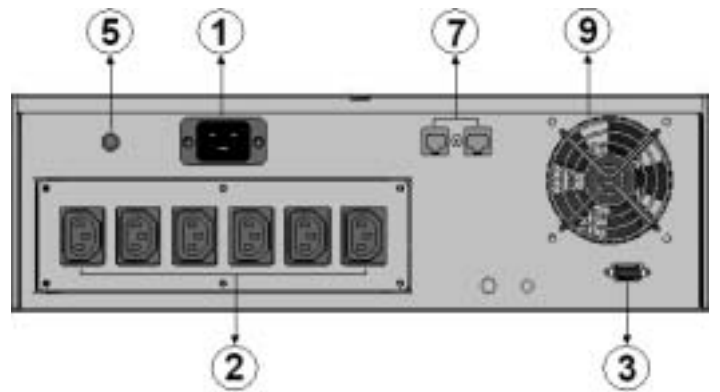
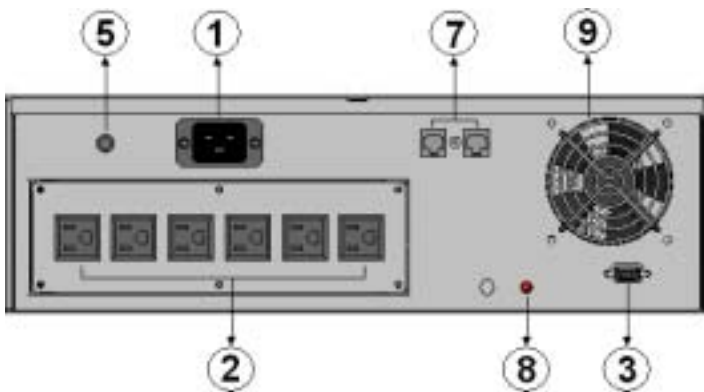

3KVA/3.5KVA

(For 110V only)

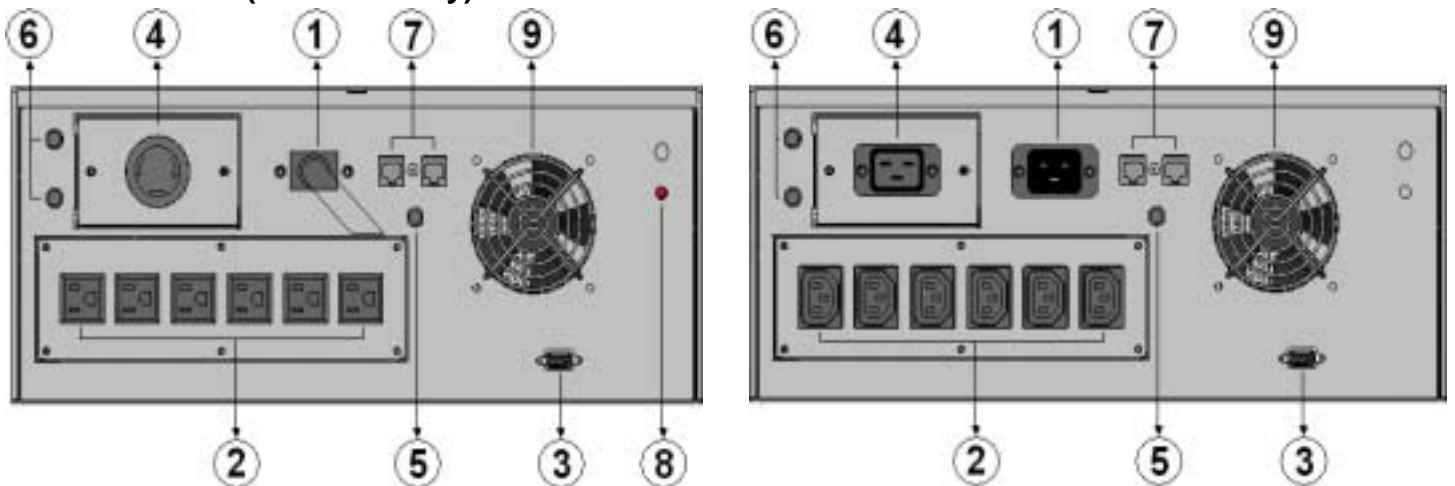

1. Input Socket / Input Power cord
2. Output Socket
3. RS-232
4. Output Socket (large circuit)(for 110v only)
5. Input Circuit Breaker
6. Output Circuit Breaker
7. RJ-45 (Network / FAX / Modem / surge Protection)
8. Site Wiring Fault LED
9. Fan

5. Installation

1. Inspection

Unpack the UPS carefully and note the packing method. Retain the box and packing material for possible future shipment. Visually inspect the UPS for freight damage. Report damage to the carrier and your dealer.

CAUTION: The UPS is heavy (see specification). Take proper precautions when lifting or moving it.

2. Placement

Locate the UPS where it cannot be accidentally disconnected. Locate it in an area with unrestricted airflow, away from water, flammable liquids, gases, or corrosives. Maintain a minimum of 100mm (4 inches) clearance around the UPS. Maintain an ambient temperature range of 0°C to 40°C (32°F to 104°F)

3. Before Connection

Shutdown load equipment, turn off mains supply and unplug load equipment's power input cable from mains supply socket.

As the color of the wires in the mains lead may not correspond with the

4. Load Connection

Connect the supplied IEC320-10 output cable between the load equipment input socket and one of the UPS AC output socket. Connect all load equipment to the UPS in the same way.

5. Turn on

Turn on the UPS by pressing the power switch for at least 0.5 second; then turn on the connected load equipment. The UPS is ready for normal operation.

6. Operation

1. Normal Mode Operation

During normal operation, mains power provides energy to the UPS. The filters and the power conditioning circuit process this power to provide computer grade power to connected loads. The UPS maintains the batteries in a fully charged state.

The front panel displays the percentage of load on the UPS output. The figure below indicates approximately 51%-75% loading.

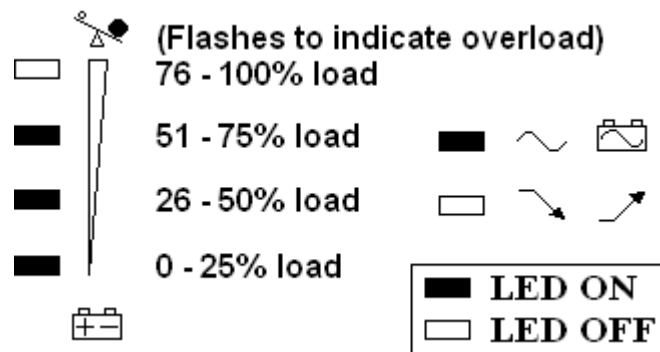

2. Mains High/Low Mode Operation

If high or low voltage conditions occur, the UPS will automatically correct the mains voltage by either lowering or raising the input voltage condition. The UPS will continue to correct these conditions indefinitely, without draining battery power.

The figure below indicates approximately 51-57% loading while automatically correcting the mains voltage.

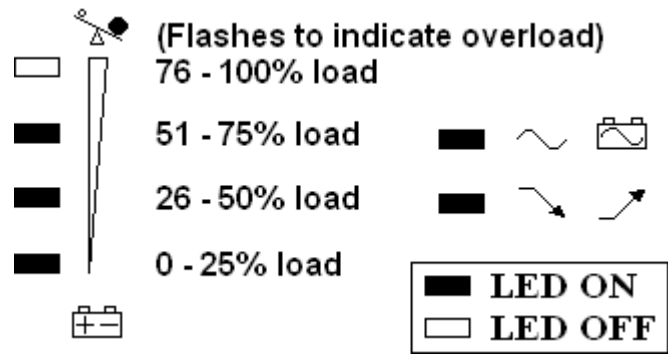

3. Battery Mode Operation

Battery mode occurs in event of extreme input voltage condition or complete mains failure. The battery system along with the bi-directional converter generates power for the connected load.

During battery mode an alarm sounds every 10 seconds. This will change to 2 beeps every 5 seconds when battery runs low (approximately 2 minutes remaining). Each load/battery level indicator represents a 25% capacity level. As capacity decreases, fewer indicators remain illuminated. Mains LED will flash every second indicating the UPS is operating from battery mode.

Battery mode supports a full rated load for approximately 5 minutes before it shuts down. To increase this time, turn off non-essential pieces of equipment (such as idle computers and monitors)

WARNING: Turning off the UPS while in battery mode will result in loss of output power.

The figure below displays approximately 51-57% battery capacity remaining.

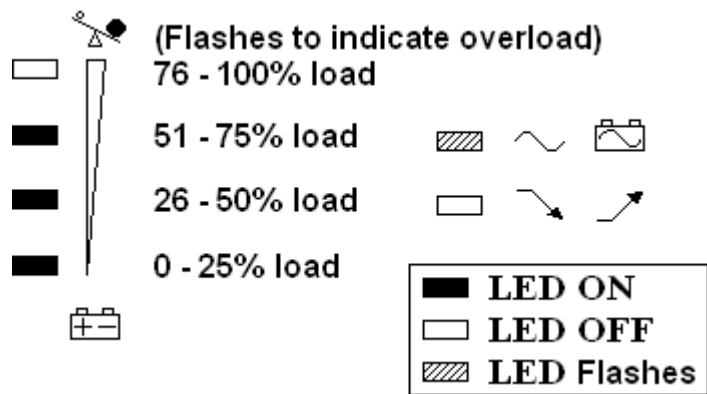

4. Battery Charge Mode

The UPS resumes normal operation once mains power is restored, whether the UPS is ON or OFF. At this time, the bi-directional converter begins recharging the battery.

7. Trouble Shooting

The information below indicates various symptoms a user may encounter in the event the UPS develops a problem. Use this information to determine whether external factors cause the problem and how to remedy the situation.

1. The fault indicator will flash every second to indicate the UPS detected a problem.
2. An alarm will sound to alert that the UPS requires attention.
3. One or more additional load/battery level LED segments will be illuminated to provide a diagnostic aid to the operator, as described below:

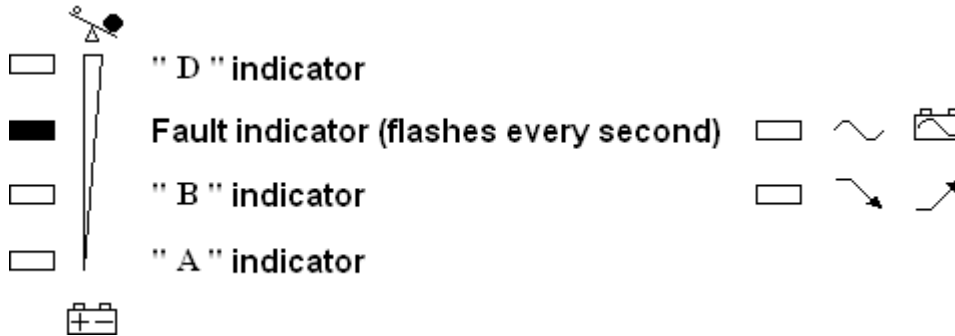

- A. UPS fault (fan failure, battery overcharge)
NOTE: The internal fan operates intermittently as needed
- B. UPS failed battery test
- D. UPS shutdown due to output overload time-out
- A.&B. UPS shutdown due to main input relay failure/output short circuit
- A.&D. UPS shutdown due to over temperature condition
- B.&D. UPS shutdown due to command from communication ports
(remote shutdown or SNMP)

The fault indicators will be illuminated indefinitely while battery charger is operational, or for a maximum of 5 minutes while battery charger is not operational.

If a problem persists, consult your dealer immediately.

Trouble Shooting Guide		
Problem	Cause	Solution
UPS fails to start when On/Off button is pressed.	UPS output short circuited or overloaded.	Ensure Ups is off. Disconnect all loads and ensure nothing is lodged in output receptacles. Ensure loads are not defective or shorted internally.
	Internal fuse is blown, indicating internal fault.	Do not attempt to open or service the Ups. Contact your dealer.

Mains indicator flashing	UPS not plugged in.	UPS is operating in battery mode. Make sure that UPS is securely plugged into the wall receptacle.
	UPS input protection has opened.	UPS is operating in battery mode. Save data and close applications. Replace UPS input fuse or reset input beaker, then restart UPS.
	Mains voltage out of UPS input range.	UPS is operating in battery mode. Save data and close applications. Ensure mains supply voltage is within acceptable limits for UPS.
UPS has reduced battery time.	Battery not charged	Keep UPS plugged in continuously at least 24 hours to recharge batteries.
	UPS is overloaded.	Check load level display and remove non-essential loads.
	Batteries may not be able to hold a full charge due to age.	Replace batteries.
“Fault” indicator and diagnostic LED “A” are illuminated.	UPS fan failure or battery overcharge.	UPS requires service. Contact your dealer.
“Fault” indicator and diagnostic LED “B” are illuminated.	UPS failed the battery test.	Replace batteries.
UPS shut down. “Fault” indicator and diagnostic LED “D” are illuminated.	UPS overloaded or load equipment is faulty.	Check load level display and remove non-essential loads. Recalculate load VA and reduce number of loads connected to Ups. Check load equipment for faults.

UPS shut down with the "Fault" indicator and diagnostic LEDs "A" and "B" are illuminated.	UPS shutdown due to internal failure.	UPS requires service. Contact your dealer.
UPS shuts down with the "Fault" indicator and diagnostic LEDs "A" and "D" are illuminated.	UPS shutdown due to an internal over temperature condition.	Ensure UPS is not overloaded, ventilation openings not blocked, or room ambient temperature not excessive. Wait 30 minutes to allow UPS to cool, then restart UPS. If it does not restart, contact your dealer.
UPS shuts down with the "Fault" indicator and diagnostic LEDs "B" and "D" are illuminated.	UPS shutdown due to a command from the communication port.	Your UPS has received a signal or command from the attached computer. If this was inadvertent, ensure the communication cable used is correct for your system. For assistance, contact your dealer.

8. Specification

MODEL	Tower type	1K/1.25K	2K/2.5K	3K/3.5K
	Rack mount type	1K/1.25K	2K/2.5K	3K/3.5K
CAPACITY	VA/W	1KVA/600W	2KVA/1200W	3KVA/1800W
		1.25KVA/750W	2.5KVA/1500W	3.5KVA/2100W
INPUT	Voltage	110VAC / 230VAC		
	Voltage Range	Acceptable Voltage Range	89-129VAC / 178-260VAC	
		Line Low Transfer	82VAC \pm 4% / 168VAC \pm 4%	
		Line Low Comeback	89VAC \pm 4% / 178VAC \pm 4%	
		Line High Transfer	136VAC \pm 4% / 272VAC \pm 4%	
Line High Comeback		129VAC \pm 4% / 260VAC \pm 4%		
OUTPUT	Voltage	110VAC / 230VAC		
	Voltage Regulation (Batt. Mode)	\pm 7%		
	Frequency	50Hz or 60Hz		
	Frequency Regulation (Batt. Mode)	\pm 0.5Hz		
	Waveform	Pure Sinewave		
TRANSFER TIME	Typical	4-6ms		

BATTERY	Tower	Battery Type*	12V/7.2Ah	12V/7.2Ah	12V/5Ah
	Rack		12V/8Ah	12V/8Ah	12V/5Ah
	Tower & Rack	Battery Type*	2 pcs	4 pcs	8 pcs
	Backup Time (at full load)		5-10 minutes (Typical)		
	Recharge Time		4 hours to 95% after discharged		
INDICATORS	AC Mode		Green LED lighting		
	Backup Mode		Green LED flashing		
	Boost/Buck		Yellow LED lighting		
	Load/Battery Level		It represents Load Level in AC Mode and Battery Level in Backup Mode. 4-segment LED bar- 0-25% : 4th LED lighting 26%-50% : 3rd and 4th LEDs lighting 51%-75% : 2nd, 3rd, and 4th LEDs lighting 76%-100% : 4 LEDs in a row all lighting		
	Low Battery		The bottom LED in a row of Load/Battery LEDs flashing every 2 seconds		
AUDIBLE ALARM	Backup Mode		Sounding every 10 seconds		
	Low Battery		Sounding every 5 seconds		
	UPS Fault		Continuously Sounding		
	Overload		Sounding every 0.5 second		
	Battery Replacement		Sounding 2 seconds every 60 seconds		
PHYSICAL	Tower	Dimension (DxWxH) mm	390x125x190	420x200x290	460x200x290
	Case	Net weight (kgs)	15 / 16	25 / 26	35 / 36
	Rack	Dimension (DxWxH) mm	375x482x85	445x482x130	445x482x172**
	Case	Net weight (kgs)	16 / 17	27 / 28	35 / 36
ENVIRONMENT	Operating Environment		0- 40°C, 0-90 % relative humidity (non-condensing)		
	Noise Level		Less than 45dB		
INTERFACE	RS-232		Support Windows 95/98/NT/2000/XP, Novell, and Linux		